

500V N-CHANNEL ENHANCEMENT MODE MOSFET

MAIN CHARACTERISTICS

I_D	8A
V_{DSS}	500V
$R_{DS(on)-typ}(@V_{GS}=10V)$	<0.85Ω (Type:0.68 Ω)

Features

- ◆Fast Switching
- ◆Low ON Resistance
- ◆Low Gate Charge
- ◆100% Single Pulse avalanche energy Test
- ◆LeadfreeincomplywithEURoHS2011/65/EUdirectives

Mechanical Data

- ◆Case: Molded plastic
- ◆Mounting Position: Any
- ◆Molded Plastic: UL Flammability Classification Rating 94V-0
- ◆Solder bath temperature275℃maximum,10s per JESD22-106

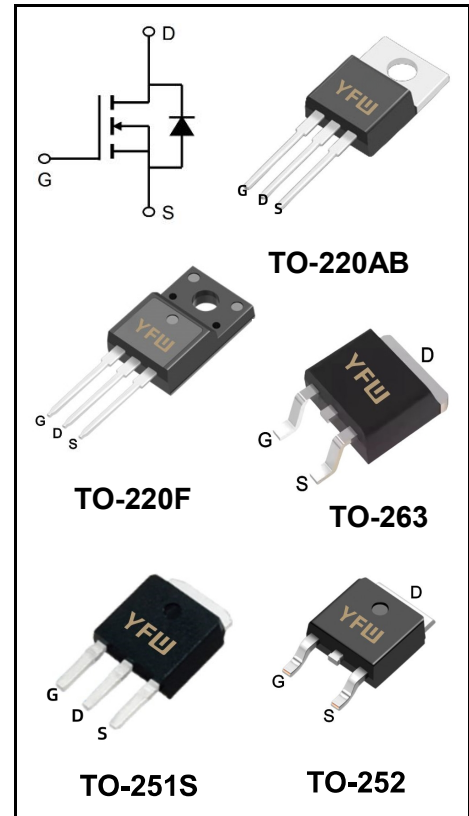

Maximum Ratings at Tc=25°C unless otherwise specified

Characteristics	Symbols	Value			Units
		220AB	220F	251/252/263	
Drain-Source Voltage	V_{DS}	500			V
Gate-Source Voltage	V_{GS}	±30			V
Continue Drain Current	I_D	8			A
-Continuous (TC = 100°C)		5.6			
Pulsed Drain Current (Note1)	I_{DM}	32			A
Power Dissipation	P_D	100	38	100	W
-Derate above 25°C		1.25	0.3	1.14	W/°C
Single Pulse Avalanche Energy (Note2)	E_{AS}	440			mJ
Avalanche Current (Note 1)	I_{AR}	8			A
Repetitive Avalanche Energy (Note 1)	E_{AS}	13			mJ
Operating Temperature Range	T_J	150			°C
Storage Temperature Range	T_{STG}	-55 to +150			°C
Thermal Resistance, Junction to Case	$R_{\theta JC}$	0.82	2.45	0.71	°C/W
Thermal Resistance, Junction to Ambient	$R_{\theta JA}$	62.5	62.5	62.5	°C/W

Maximum Ratings at Tc=25°C unless otherwise specified

Characteristics	Test Condition	Symbols	Min	Typ	Max	Units
Drain-Source Breakdown Voltage	$V_{GS} = 0 V, I_D = 250 \mu A$	BV_{DSS}	500	-	-	V
Breakdown Voltage Temperature Coefficient	$I_D = 250 \mu A$ (Referenced to 25°C)	$\frac{\Delta BV_{DSS}}{\Delta T_J}$	-	0.65	-	V/°C
Drain-Source Leakage Current	$V_{DS} = 500 V, V_{GS} = 0 V$	I_{DSS}	-	-	1	uA
	$V_{DS} = 400 V, T_c = 125^\circ C$		-	-	10	
Gate Leakage Current	$V_{GS} = \pm 30 V, V_{DS} = 0 V$	I_{GSS}	-	-	±100	nA
Gate-Source Threshold Voltage	$V_{DS} = V_{GS}, I_D = 250 \mu A$	$V_{GS(th)}$	2	-	4	V
Drain-Source On-State Resistance	$V_{GS} = 10 V, I_D = 4 A$	$R_{DS(on)}$	-	0.68	0.85	Ω
Forward Transconductance	$V_{DS} = 15 V, I_D = 4 A$	g_{fs}	-	7	-	S
Input Capacitance	$V_{GS} = 0 V, V_{DS} = 25 V,$ $f = 1 MHz$	C_{iss}	-	891	-	pF
Output Capacitance		C_{oss}	-	110	-	
Reverse Transfer Capacitance		C_{rss}	-	7	-	
Turn-on Delay Time	$I_D = 8 A, V_{DD} = 250 V,$ $R_G = 10 \Omega$ (Note3,4)	$td(ON)$	-	18	-	nS
Rise Time		tr	-	20	-	
Turn-Off Delay Time		$td(OFF)$	-	44	-	
Fall Time		tf	-	15	-	
Total Gate Charge	$I_D = 8 A, V_{DD} = 400 V,$ $V_{GS} = 10 V$ (Note3,4)	Q_G	-	22	-	nC
Gate to Source Charge		Q_{GS}	-	5	-	
Gate to Drain Charge		Q_{GD}	-	9	-	

Source-Drain Diode Characteristics at Ta=25°C unless otherwise specified

Characteristics	Test Condition	Symbols	Min	Typ	Max	Units
Maximum Continuous Drain-Source Diode Forward Current		I_S	-	-	8	A
Maximum Pulsed Drain-Source Diode Forward Current		I_{SM}	-	-	32	A
Drain-Source Diode Forward Voltage	I_{SD} = 8 A	V_{SD}	-	-	1.4	V
Reverse Recovery Time	I_{SD} = 8 A, V_{GS} = 0 V, dI_F / dt = 100 A/μs	trr	-	340	-	nS
Reverse Recovery Charge		Qrr	-	1.7	-	uC

Note:

1. Repetitive Rating: Pulse width limited by maximum junction temperature.
2. IAS =8 A, VDD = 50 V, L =14mH, RG = 25Ω, starting TJ = 25°C.
3. ulse test: Pulse Width ≤300 μ s, Duty Cycle≤2%.
4. Essentially Independent of Operating Temperature.

Ratings and Characteristic Curves

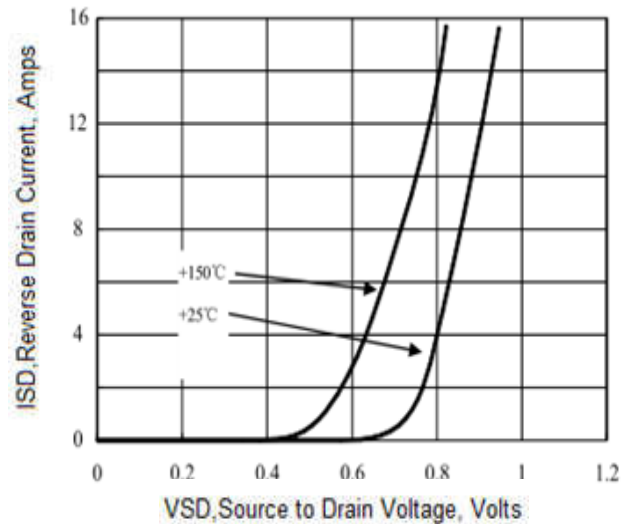
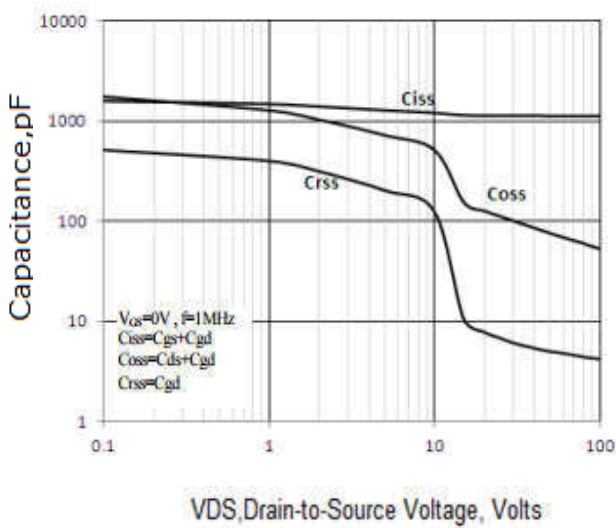
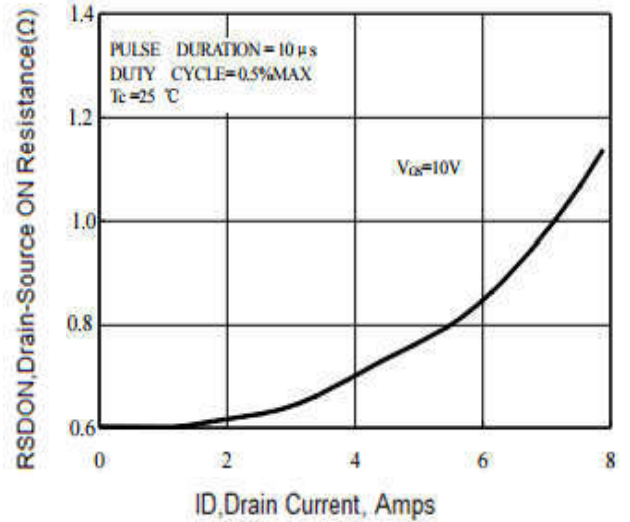
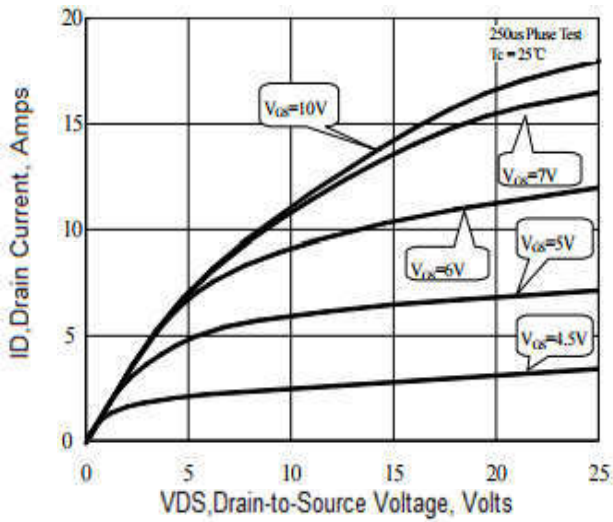
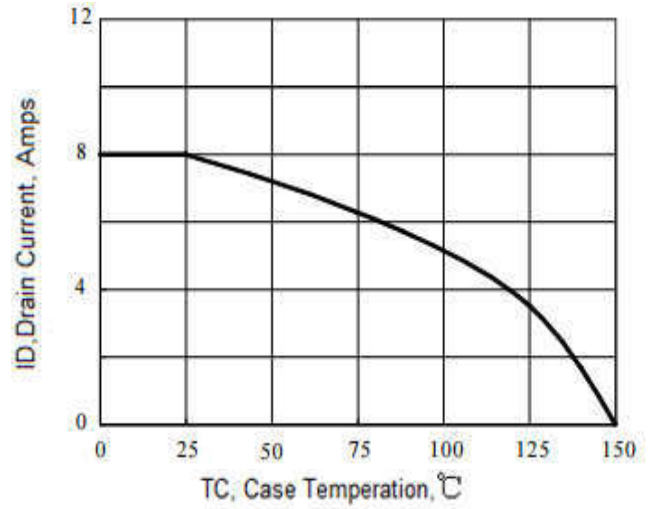
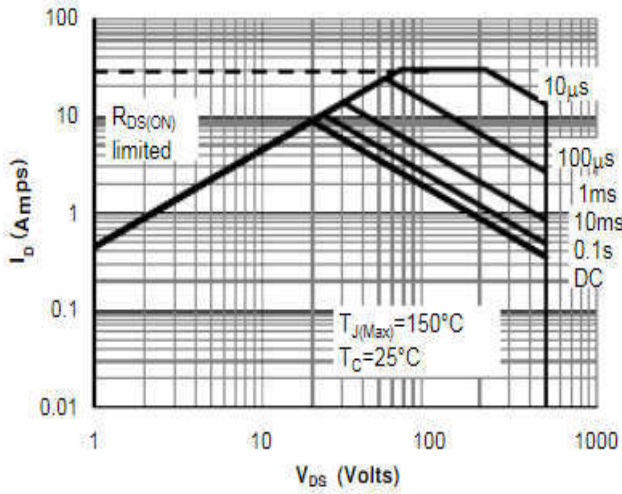

Marking Diagram

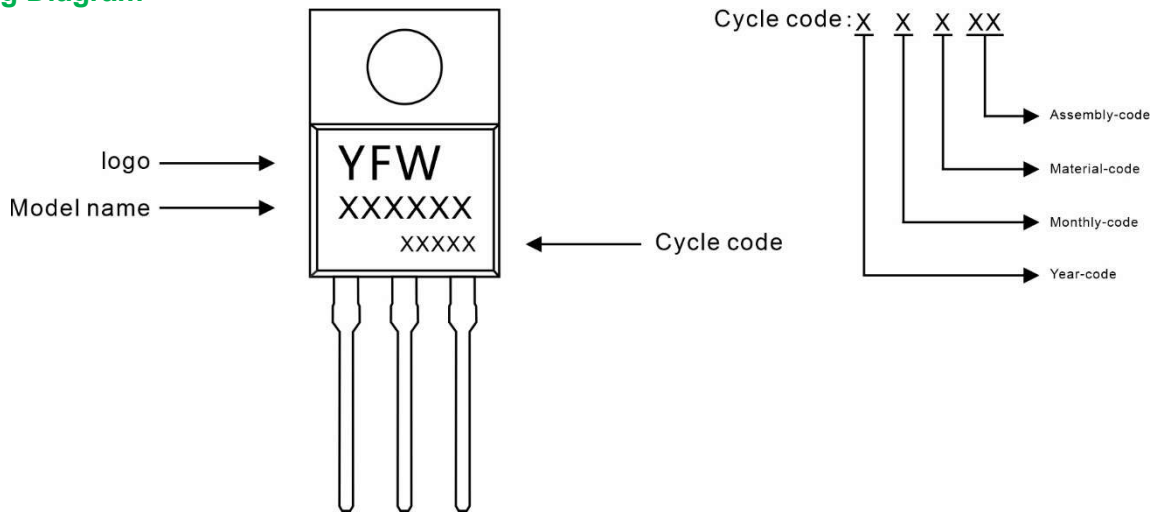

Ordering information

Model name	Package	Unit Weight	Base Quantity	Packing Quantity
YFW8N50AT	TO-220AB	0.07oz(1.96g)	50pcs/tube	1000PCS/Box 5000PCS/Carton

Package Dimensions

TO-220AB

Symbol	Millimeter		Inches	
	Min.	Max.	Min.	Max.
A	4.30	4.70	0.169	0.185
A1	2.52	2.82	0.099	0.111
b	0.71	0.91	0.028	0.036
b1	1.17	1.37	0.046	0.054
c	0.30	0.50	0.012	0.020
c1	1.17	1.37	0.046	0.054
D	9.90	10.20	0.390	0.402
E	8.50	8.90	0.335	0.350
E1	12.00	12.50	0.472	0.492
e	2.44	2.64	0.096	0.104
e1	4.88	5.28	0.192	0.208
F	2.60	2.80	0.102	0.110
L	13.20	13.80	0.520	0.543
L1	3.80	4.20	0.150	0.165
Φ	3.60	3.96	0.142	0.156

Marking Diagram

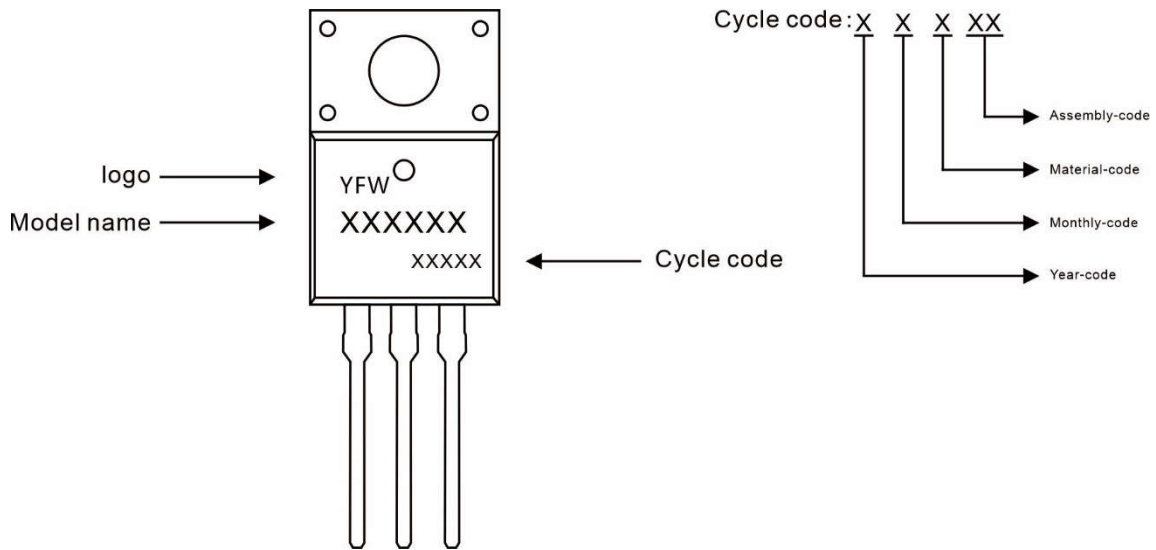

Ordering information

Model name	Package	Unit Weight	Base Quantity	Packing Quantity
YFW8N50AF	TO-220F	0.06oz(1.74g)	50pcs/tube	1000PCS/Box 5000PCS/Carton

Package Dimensions

TO-220F

Symbol	Millimeter		Inches	
	Min.	Max.	Min.	Max.
A	4.50	4.90	0.177	0.193
A1	2.34	2.74	0.092	0.108
A2	2.66	2.86	0.105	0.113
b	0.75	0.85	0.030	0.033
b1	1.24	1.44	0.049	0.057
c	0.40	0.60	0.016	0.024
D	10.00	10.32	0.394	0.406
E	15.75	16.05	0.620	0.632
e	2.44	2.64	0.096	0.104
e1	4.88	5.28	0.192	0.208
F	3.10	3.5	0.122	0.138
L	13.50	13.90	0.531	0.547
L1	2.90	3.30	0.114	0.130
Φ	3.10	3.30	0.122	0.130

Marking Diagram

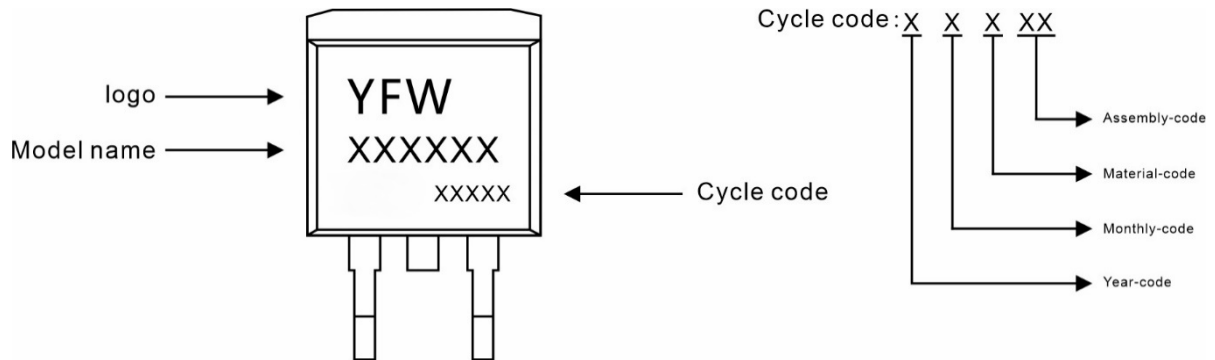

Ordering information

Model name	Package	Unit Weight	Base Quantity	Packing Quantity
YFW8N50AS	TO-263	0.04oz(1.16g)	800pcs/reel	1600pcs/box 8000pcs/Carton

Package Dimensions

TO-263

Dim	Millimeter		Inches	
	Min.	Max.	Min.	Max.
A	4.30	4.70	0.169	0.185
A1	0.00	0.15	0.000	0.006
A2	4.30	4.55	0.169	0.179
B	1.10	1.50	0.043	0.059
b	0.70	0.90	0.028	0.035
b1	1.20	1.50	0.047	0.059
c	0.30	0.60	0.012	0.024
c1	1.17	1.37	0.046	0.054
D	9.90	10.20	0.390	0.402
E	8.50	8.90	0.335	0.350
e	2.44	2.64	0.096	0.104
e1	4.88	5.28	0.192	0.208
L	15.00	15.30	0.591	0.602
L1	5.20	5.40	0.205	0.213
L2	2.40	2.60	0.094	0.102
L3	1.60	1.80	0.063	0.071

Marking Diagram

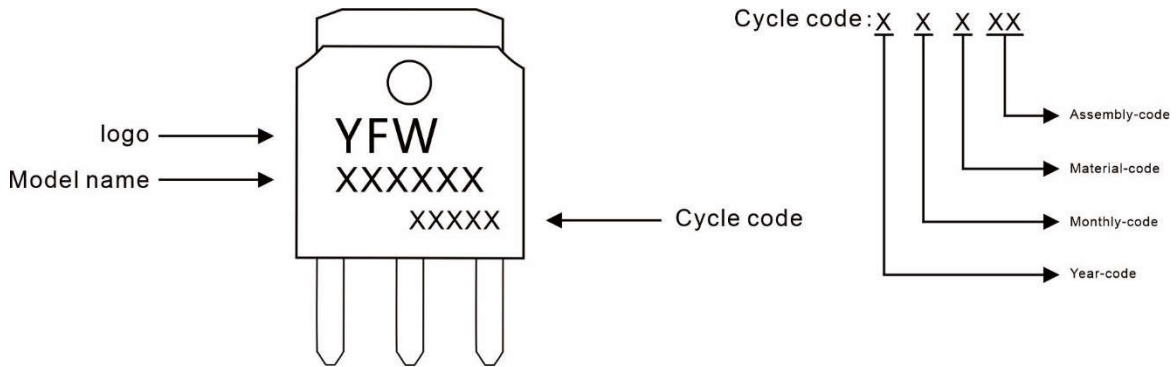

Ordering information

Model name	Package	Unit Weight	Base Quantity	Packing Quantity
YFW8N50AMJ	TO-251S	0.011oz(0.32g)	80pcs/tube	4000pcs/box 24000pcs/Carton

Package Dimensions

TO-251S

Dim	Millimeter		Inches	
	Min.	Max.	Min.	Max.
A	2.1	2.5	0.083	0.098
A1	6.3	6.9	0.248	0.271
A2	0.9	1.1	0.035	0.043
A3	TYP0.5		TYP0.019	
b	0.6	0.8	0.024	0.031
c	0.4	0.5	0.015	0.020
D	5.3	5.5	0.209	0.217
D2	3.65	4.05	0.144	0.159
E	5.8	6.4	0.228	0.252
E2	0.9	1.4	0.035	0.055
e	TYP2.29		TYP0.090	
e1	TYP4.58		TYP0.180	
L	3.7	4.3	0.146	0.169

Marking Diagram

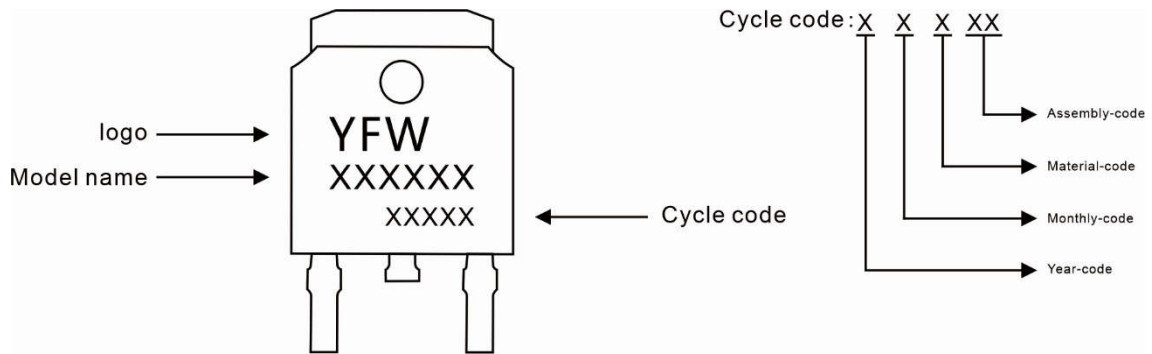

Ordering information

Model name	Package	Unit Weight	Base Quantity	Packing Quantity
YFW8N50AD	TO-252	0.011oz(0.32g)	2500pcs/reel	5000pcs/box 25000pcs/Carton

Package Dimensions

TO-252

Dim	Millimeter		Inches	
	Min.	Max.	Min.	Max.
A	2.20	2.50	0.087	0.098
A1	0.00	0.12	0.000	0.005
A2	2.20	2.40	0.087	0.094
B	1.20	1.60	0.047	0.063
b	0.50	0.70	0.020	0.028
b1	0.70	0.90	0.028	0.035
c	0.40	0.60	0.016	0.024
c1	0.40	0.60	0.016	0.024
D	6.35	6.65	0.250	0.262
D1	5.20	5.40	0.205	0.213
E	5.40	5.70	0.213	0.224
e	2.20	2.40	0.087	0.094
e1	4.40	4.80	0.173	0.189
L	10.00	11.00	0.393	0.433
L1	2.70	3.10	0.106	0.122
L2	1.40	1.80	0.055	0.071
L3	0.90	1.50	0.035	0.059

Disclaimer

The information presented in this document is for reference only. Guangdong Youfeng Microelectronics Co.,Ltd. reserves the right to make changes without notice for the specification of the products displayed herein to improve reliability, function or design or otherwise. The product listed herein is designed to be used with ordinary electronic equipment or devices, and not designed to be used with equipment or devices which require high level of reliability and the malfunction of which would directly endanger human life (such as medical instruments, transportation equipment, aerospace machinery, nuclear-reactor controllers, fuel controllers and other safety devices), YFW or anyone on its behalf, assumes no responsibility or liability for any damages resulting from such improper use of sale. This publication supersedes & replaces all information previously supplied. For additional information, please visit our website <https://www.yfwdiode.com>, or consult YFW sales office for further assistance.