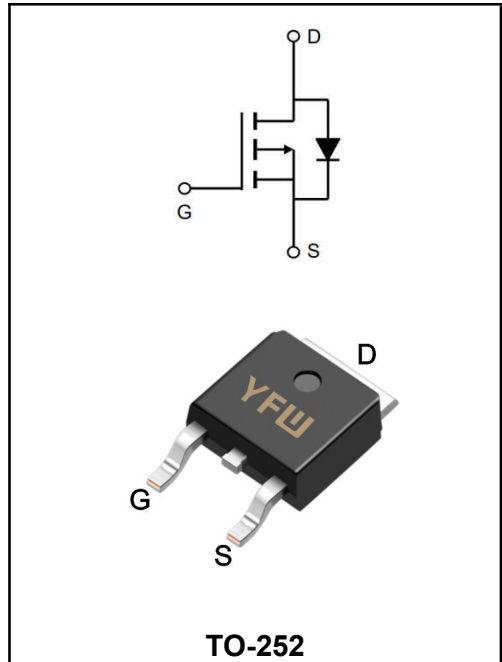


**-20V P-CHANNEL ENHANCEMENT MODE MOSFET**

**MAIN CHARACTERISTICS**

<b>I<sub>D</sub></b>	-60A
<b>V<sub>DS</sub></b>	-20V
<b>R<sub>DS(on)-typ</sub>(@V<sub>GS</sub>=-4.5V)</b>	< 8.5mΩ ( <b>Typ:6.6mΩ</b> )
<b>R<sub>DS(on)-typ</sub>(@V<sub>GS</sub>=-2.5V)</b>	< 13mΩ ( <b>Typ:8.0mΩ</b> )



**DESCRIPTION**

The YFW60P02AD uses advanced trench technology to provide excellent R<sub>os(on)</sub>, low gate charge and operation with gate voltages as low as 2.5V. This device is suitable for use as a Battery protection or in other Switching application.

**Application**

- ♣ 3.3V MCU Drive
- ♣ Load switch
- ♣ Uninterruptible power supply

**Absolute Maximum Ratings (T<sub>c</sub>=25°C unless otherwise noted)**

Characteristics	Symbols	Value	Units
Drain-Source Voltage	<b>V<sub>DS</sub></b>	-20	<b>V</b>
Gate - Source Voltage	<b>V<sub>GS</sub></b>	± 12	<b>V</b>
Continuous Drain Current, V <sub>GS</sub> @ -4.5V @T <sub>A</sub> =25°C	<b>I<sub>D</sub></b>	-60	<b>A</b>
Continuous Drain Current, V <sub>GS</sub> @ -4.5V @T <sub>A</sub> =70°C	<b>I<sub>D</sub></b>	-40	<b>A</b>
Pulsed Drain Current <sup>1</sup>	<b>I<sub>DM</sub></b>	-210	<b>A</b>
Single Pulsed Avalanche Energy <sup>2</sup>	<b>E<sub>AS</sub></b>	147.6	<b>mJ</b>
Total Power Dissipation @T <sub>A</sub> =25°C	<b>P<sub>D</sub></b>	78	<b>W</b>
Thermal Resistance Junction-Ambient <sup>1</sup>	<b>R<sub>θJA</sub></b>	62	<b>°C/W</b>
Thermal Resistance Junction to Case	<b>R<sub>θJC</sub></b>	1.6	<b>°C/W</b>
Storage Temperature Range	<b>T<sub>STG</sub></b>	-55 to +150	<b>°C</b>
Operating Junction Temperature Range	<b>T<sub>J</sub></b>	-55 to +150	<b>°C</b>

**Electrical Characteristics (T<sub>J</sub>=25°C, unless otherwise noted)**

Characteristics	Test Condition	Symbols	Min	Typ	Max	Units
Drain-Source Breakdown Voltage	V <sub>GS</sub> =0V, I <sub>D</sub> =-250μA	V <sub>(BR)DSS</sub>	-20	-24	-	V
Zero Gate Voltage Drain Current	V <sub>DS</sub> = -20V, V <sub>GS</sub> =0V,	I <sub>DSS</sub>	-	-	- 1.0	μA
Gate to Body Leakage Current	V <sub>DS</sub> =0V, V <sub>GS</sub> =±12V	I <sub>GSS</sub>	-	-	±100	nA
Gate Threshold Voltage	V <sub>DS</sub> =V <sub>GS</sub> , I <sub>D</sub> =-250μA	V <sub>GS(th)</sub>	- 0.5	- 1.0	- 1.5	V
Static Drain-Source on-Resistance <sup>3</sup>	V <sub>GS</sub> = - 4.5V, I <sub>D</sub> =-20A	R <sub>DS(ON)</sub>	-	6.6	8.5	mΩ
	V <sub>GS</sub> = - 2.5V, I <sub>D</sub> =-10A		-	8.0	13	
Input Capacitance	V <sub>DS</sub> = -10V V <sub>GS</sub> =0V f=1.0MHz	C <sub>iss</sub>	-	1458	-	pF
Output Capacitance		C <sub>oss</sub>	-	238	-	pF
Reverse Transfer Capacitance		C <sub>rss</sub>	-	212	-	pF
Total Gate Charge		Q <sub>g</sub>	-	19	-	nC
Gate-Source Charge	V <sub>DS</sub> = -10V, I <sub>D</sub> =-25A, V <sub>GS</sub> =-4.5V	Q <sub>gs</sub>	-	3	-	nC
Gate-Drain("Miller") Charge		Q <sub>gd</sub>	-	6.4	-	nC
Turn-on Delay Time	V <sub>DS</sub> = -10V I <sub>D</sub> = -10A R <sub>GEN</sub> =3Ω V <sub>GS</sub> = - 4.5V	t <sub>d(on)</sub>	-	10	-	ns
Turn-on Rise Time		T <sub>r</sub>	-	21	-	ns
Turn-off Delay Time		t <sub>d(OFF)</sub>	-	39	-	ns
Turn-off Fall Time		t <sub>f</sub>	-	19	-	ns
Maximum Continuous Drain to Source Diode Forward Current		I <sub>S</sub>	-	-	- 60	A
Maximum Pulsed Drain to Source Diode Forward Current		I <sub>SM</sub>	-	-	- 210	A
Drain to Source Diode Forward Voltage	V <sub>GS</sub> =0V, I <sub>S</sub> = -30A	V <sub>SD</sub>	-	-	- 1.2	V
Body Diode Reverse Recovery Time	IF= -20A, dI/dt=100A/μs	t <sub>rr</sub>	-	25	-	ns
Body Diode Reverse Recovery Charge		Q <sub>rr</sub>	-	20	-	nC

**Note :**

- 1.The data tested by surface mounted on a 1 inch<sup>2</sup> FR-4 board with 2OZ copper.
- 2.The data tested by pulsed , pulse width ≅ 300us , duty cycle ≅ 2%
- 3.The test condition is T<sub>J</sub>=25°C, V<sub>DD</sub>=10V, V<sub>G</sub>=4.5V, L=0.5mH, R<sub>G</sub>=25Ω, I<sub>AS</sub>=12A
- 4.The power dissipation is limited by 150°C junction temperature
- 5.The data is theoretically the same as ID and IDM , in real applications , should be limited by total power dissipation.

Typical Characteristics

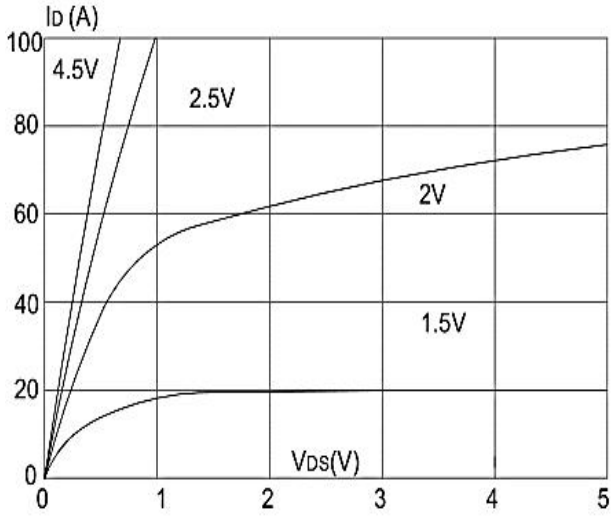


Figure 1: Output Characteristics

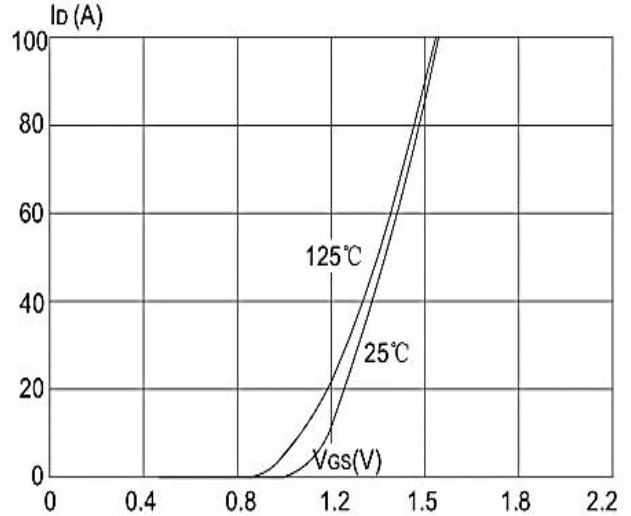


Figure 2: Typical Transfer Characteristics

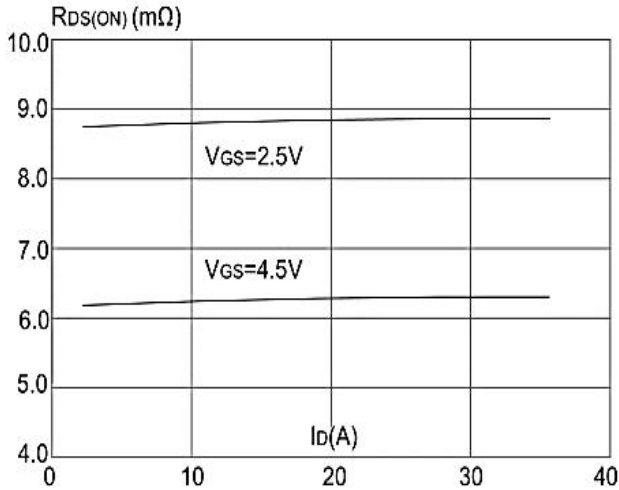


Figure 3: On-resistance vs. Drain Current

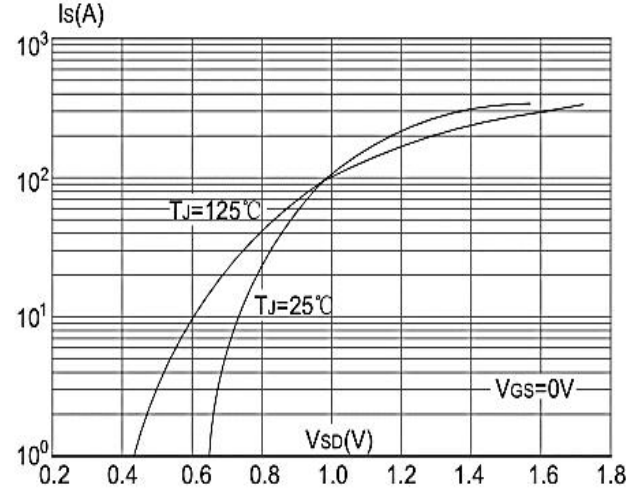


Figure 4: Body Diode Characteristics

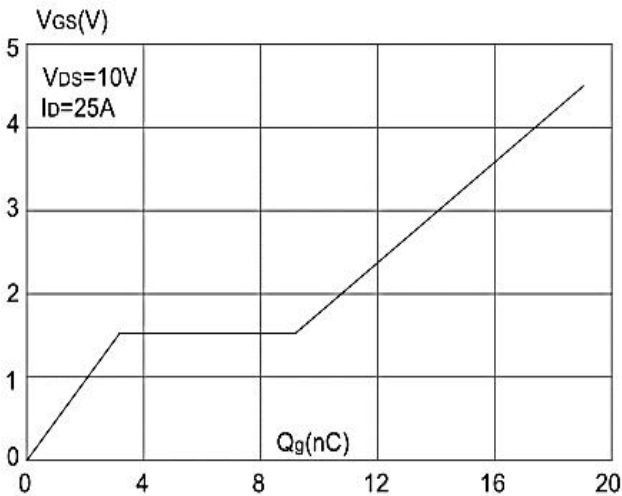


Figure 5: Gate Charge Characteristics

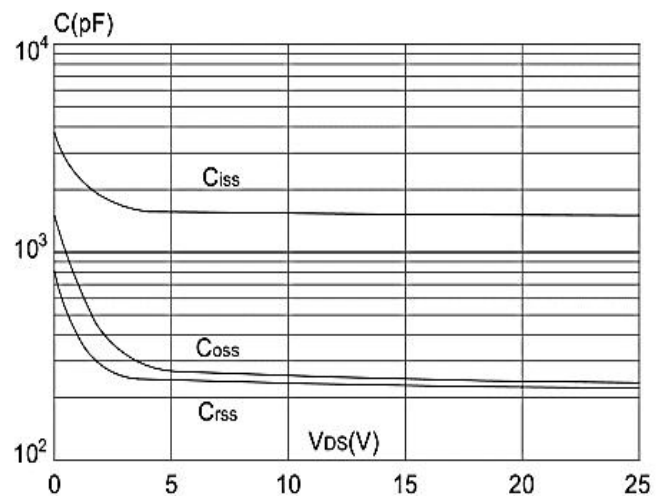
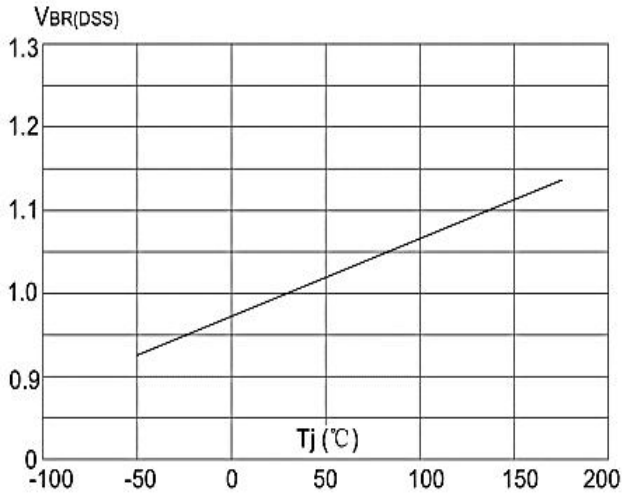
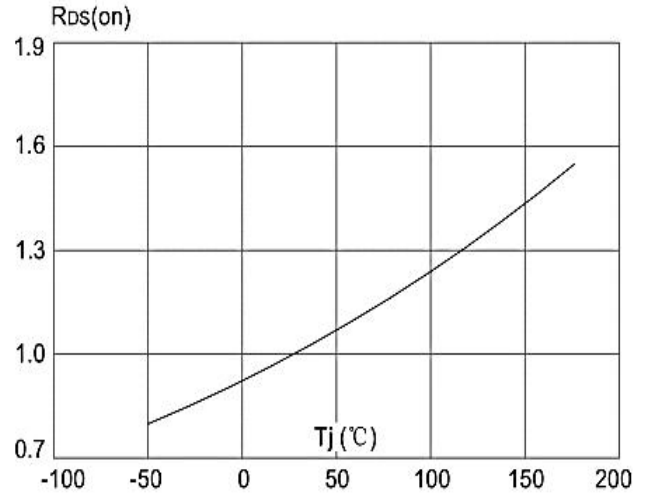


Figure 6: Capacitance Characteristics

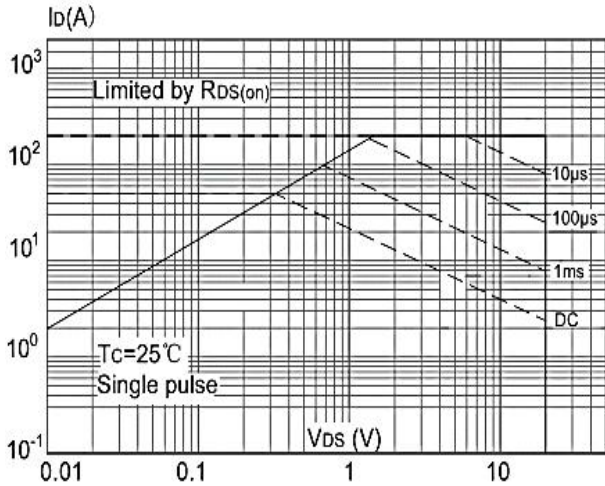
Typical Characteristics



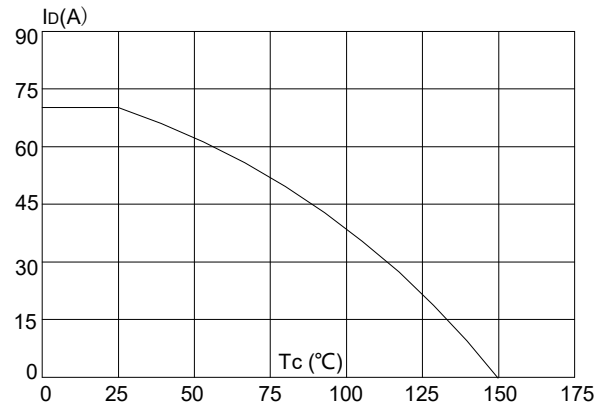
**Figure 7: Normalized Breakdown Voltage vs. Junction Temperature**



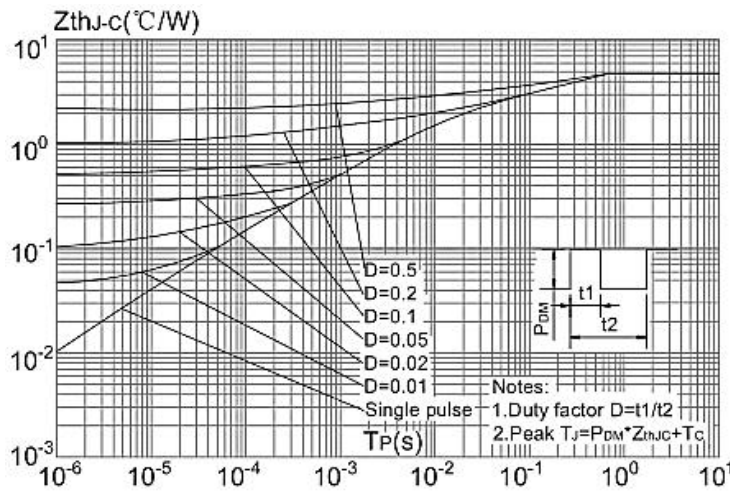
**Figure 8: Normalized on Resistance vs. Junction Temperature**



**Figure 9: Maximum Safe Operating Area vs. Case Temperature**

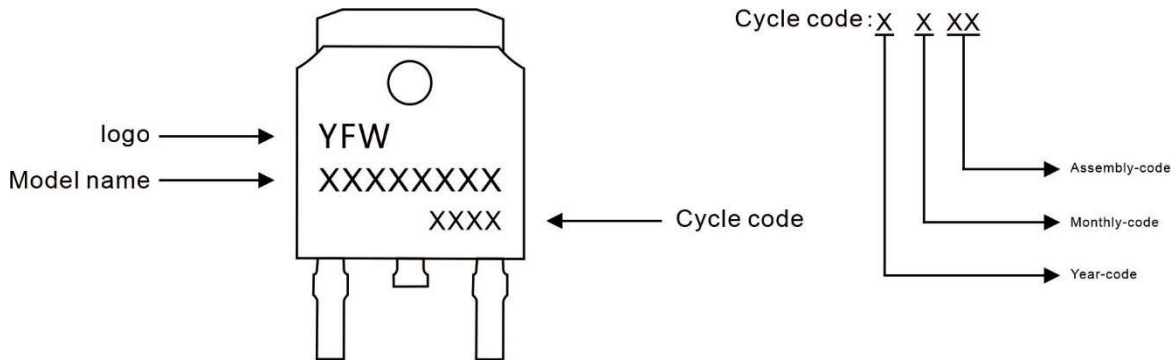


**Figure 10: Maximum Continuous Drain Current vs. Case Temperature**



**Figure.11: Maximum Effective Transient Thermal Impedance Junction-to-Case**

**Marking Diagram**



**Ordering information**

Model name	Package	Unit Weight	Base Quantity	Packing Quantity
YFW60P02AD	TO-252	0.011oz(0.32g)	2500pcs/reel	5000pcs/box 25000pcs/Carton

**Package Dimensions**

**TO-252**

Dim	Millimeter		Inches	
	Min.	Max.	Min.	Max.
A	2.20	2.50	0.087	0.098
A1	0.00	0.12	0.000	0.005
A2	2.20	2.40	0.087	0.094
B	1.20	1.60	0.047	0.063
b	0.50	0.70	0.020	0.028
b1	0.70	0.90	0.028	0.035
c	0.40	0.60	0.016	0.024
c1	0.40	0.60	0.016	0.024
D	6.35	6.65	0.250	0.262
D1	5.20	5.40	0.205	0.213
E	5.40	5.70	0.213	0.224
e	2.20	2.40	0.087	0.094
e1	4.40	4.80	0.173	0.189
L	10.00	11.00	0.393	0.433
L1	2.70	3.10	0.106	0.122
L2	1.40	1.80	0.055	0.071
L3	0.90	1.50	0.035	0.059

## Disclaimer

The information presented in this document is for reference only. Guangdong Youfeng Microelectronics Co.,Ltd. reserves the right to make changes without notice for the specification of the products displayed herein to improve reliability, function or design or otherwise. The product listed herein is designed to be used with ordinary electronic equipment or devices, and not designed to be used with equipment or devices which require high level of reliability and the malfunction of which would directly endanger human life (such as medical instruments, transportation equipment, aerospace machinery, nuclear-reactor controllers, fuel controllers and other safety devices), YFW or anyone on its behalf, assumes no responsibility or liability for any damages resulting from such improper use of sale. This publication supersedes & replaces all information previously supplied. For additional information, please visit our website <https://www.yfwdiode.com>, or consult YFW sales office for further assistance.